



Low-voltage Adjustable Precision Shunt Regulators

GENERAL DESCRIPTION

The LND431LV are three-terminal low-voltage adjustable shunt regulators with specified thermal stability. The output voltage may be set to any value between V_{ref} (approximately 1.24V) and 6V with two external resistors. These devices have typical output impedance of 0.2Ω .

FEATURES

- Equivalent Full-Range Temperature Coefficient 30ppm/°C
- Temperature Compensated for Operation Over Full Rated Operating Temperature Range
- Adjustable Output Voltage
- Sink Current Capability 1mA to 100mA
- Low ($0.2\ \Omega$ Typ) Dynamic Output Impedance
- Low Output Noise

PIN CONFIGURATION

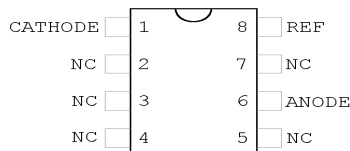
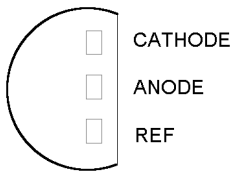

SYMBOL





ABSOLUTE MAXIMUM RATINGS

PARAMETER	VALUE	UNITS
Cathode voltage (see note 1)	7	V
Continuous cathode current range	-20 to 20	mA
Reference input current range	-.050 to 3.0	
Operating free-air temperature range	0 to 70	°C
Lead temperature 1.6mm from case for 10 seconds	260	

Note1: Voltage values are with respect to the anode terminal unless otherwise noted

RECOMMENDED OPERATING CONDITIONS

PARAMETER	VALUE	MAX	UNITS
Cathode voltage, V_{KA}	V_{ref}	6	V
Cathode current, I_k (for regulation)	.1	15	mA

FUNCTIONAL BLOCK DIAGRAM

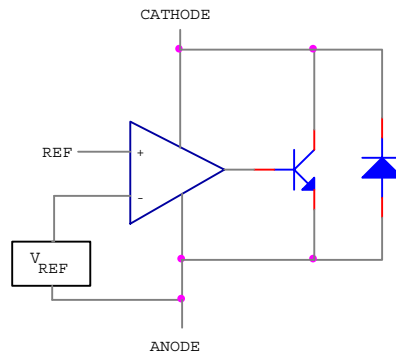



ELECTRICAL CHARACTERISTICS

PARAMETER	SYMBOL	TEST CIRCUIT	TEST CONDITIONS	MIN	TYP	MAX	UNIT
Reference input voltage	V_{ref}	1	$V_{KA} = V_{ref}, I_k = 10mA$	1222	1240	1258	mV
Deviation of reference input voltage over full temperature range	$V_{ref(dev)}$	1	$V_{KA} = V_{ref}, I_k = 10mA, T_A = \text{Full range}$		4	12	
Ratio of change in reference input voltage to the change in cathode voltage	$\Delta V_{ref}/\Delta V_{KA}$	2	$I_k = 10mA, \Delta V_{KA} = 6V \text{ to } V_{ref}$		-1.4	-2.7	mV/V
Reference input current	I_{ref}	2	$I_k = 10mA, R1 = 10K\Omega, R2 = \infty, T_A = \text{full range}$		0.15	0.5	μA
Deviation of reference input current over full temperature range	$I_{ref(dev)}$	2	$I_k = 10mA, R1 = 10K\Omega, R2 = \infty, T_A = \text{full range}$		0.05	0.3	
Minimum cathode current for regulation	I_{min}	1	$V_{KA} = V_{ref}$		55	80	μA
Off- state cathode current	I_{off}	3	$V_{KA} = 6V, V_{ref} = 0$		0.001	1	μA
Dynamic impedance	$ Z_{KA} $	1	$V_{KA} = V_{ref}, I_k = 1mA \text{ to } 100mA, f \leq 1KHz$		0.2	0.4	Ω

PARAMETER MEASUREMENT INFORMATION

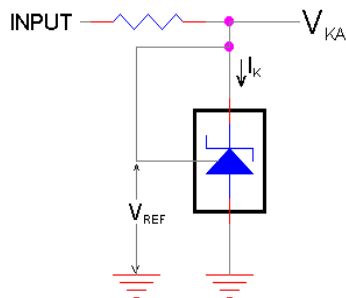

Test Circuit 1. For $V_{KA} = V_{REF}$

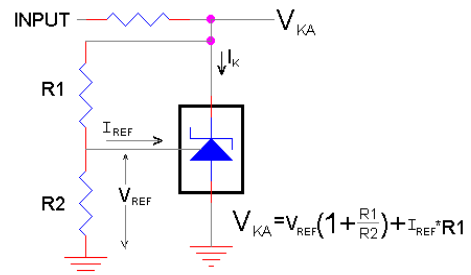

Test Circuit 2. For $V_{KA} > V_{REF}$



PARAMETER MEASUREMENT INFORMATION

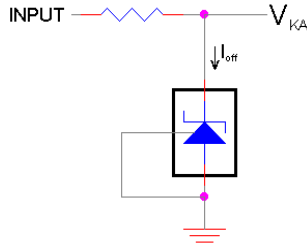

Test Circuit 3. For I_{OFF}

TYPICAL CHARACTERISTICS

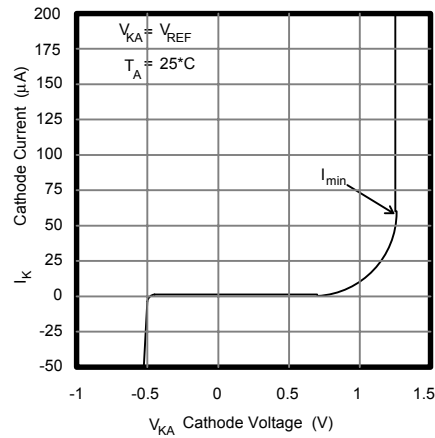
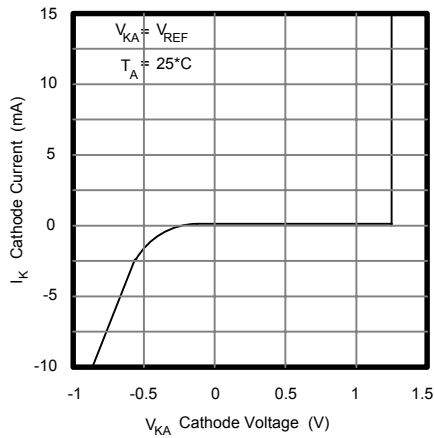

Cathode Current v/s Cathode Voltage

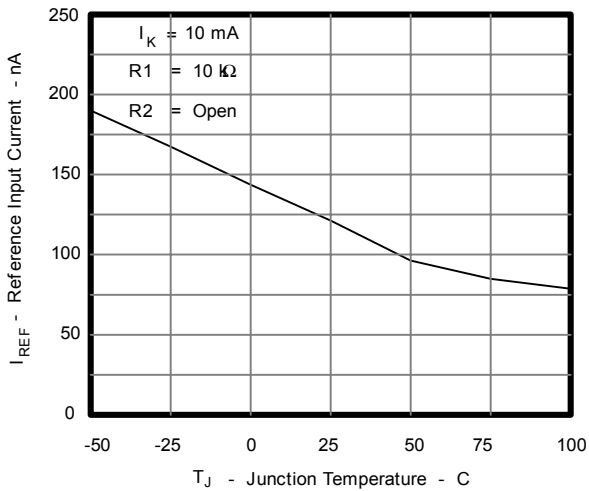

Ref Voltage v/s Junction Temperature

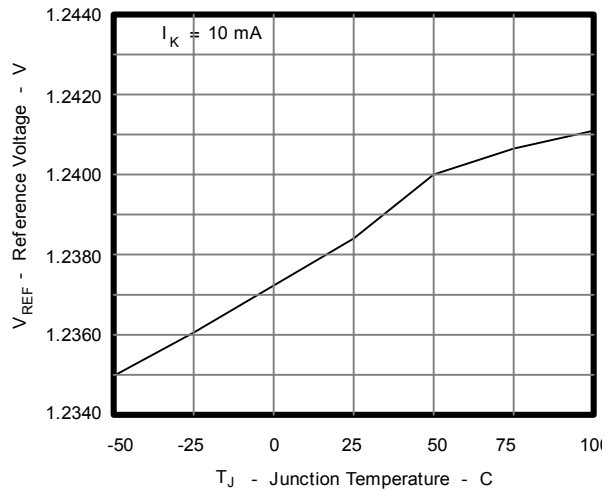

Ref Input Current v/s Junction Temperature



Stability Boundary Condition

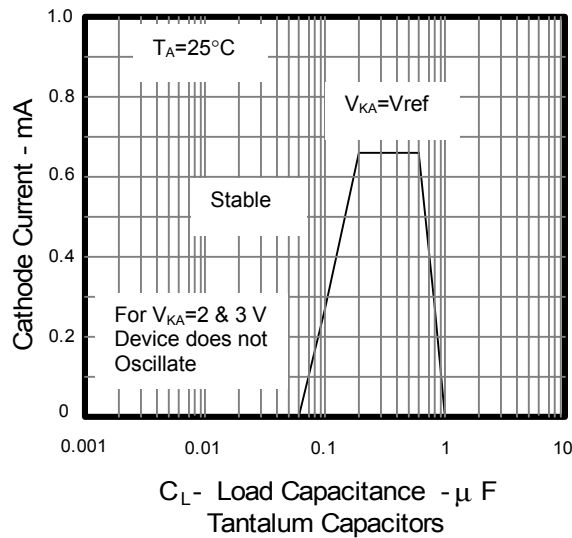
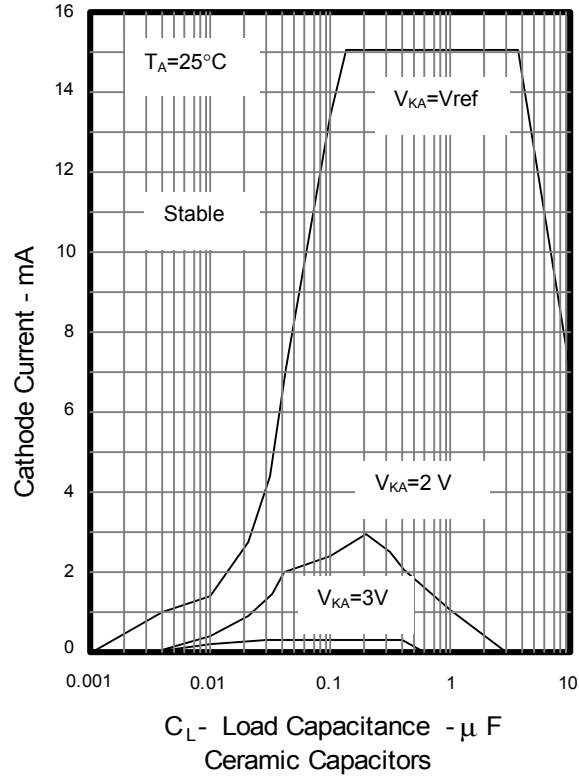

* Stability boundary condition test shows that tantalum capacitors are recommended to minimize the conditions that may cause the device to oscillate.

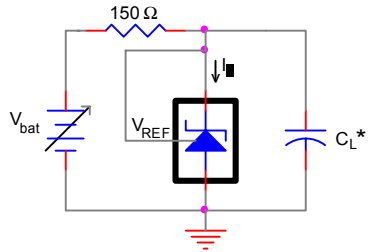

TEST CIRCUIT FOR $V_{KA} = V_{REF}$

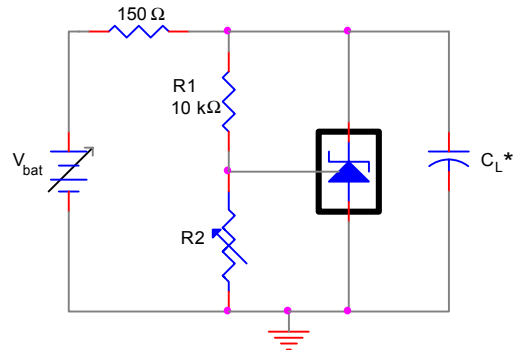

TEST CIRCUIT FOR $V_{KA} = 2\text{ V}, 3\text{ V}$

The Areas under the curves represent conditions that may cause the device to oscillate. For $V_{KA} = 2\text{ V}$ and 3 V curves, R_2 and V_{bat} were adjusted to establish the initial V_{KA} and I_K conditions with $C_L = 0$. V_{bat} and C_L then were adjusted to determine the ranges of stability.

TYPICAL APPLICATIONS

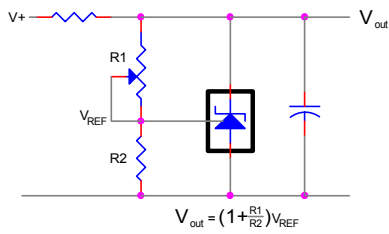

Figure 1. Shunt Regulator

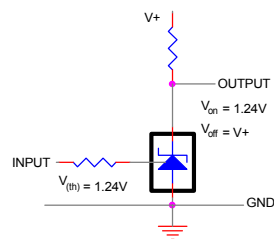

Figure 2. Single-supply comparator
With temperature compensated threshold